

Duct Temperature Sensor

Product Description

Active output and passive resistance sensors with plastic housing for acquiring air temperature in air ducts.

Product Number

Type	Product Number	Sensing Output	Probe Length
Passive Resistance	QAM2112.040	Platinum 1K Ω , 385 alpha	16 inches
	QAM2112.200	Platinum 1K Ω , 385 alpha	6.5 feet
	QAM2130.040	NTC 10K Ω , Type 2	16 inches
Active Output	QAM2161.040	0 to 10 Vdc signal [Platinum 1K Ω]	16 inches
	QAM2171.040	4 to 20 mA signal [Platinum 1K Ω]	16 inches

Required Tools

- Drill
- 7/8-inch drill bit
- Screwdriver

Expected Installation Time

45 minutes

Prerequisites

- Field wiring must be pulled to utility box near installation point. (14 AWG to 16 AWG)
- Mounting Clamps (AQM63.3), if required by mounting configuration.

Installation

Depending on the use, locate the duct sensor as follows:

- For supply air temperature control: If the fan is located after the last air handling unit, install downstream from the fan. Otherwise, mount after the last air handling unit with a minimum distance of 1.6 feet (0.5 m).

- For exhaust air temperature control: Always mount upstream of the exhaust air fan.
- As a limit sensor for supply air temperature: Mount as close as possible to the air outlet into the room.
- For dewpoint control: Mount sensor immediately after the spray trap of the air washer.

Manually bend the probe so that it lies diagonally across the duct or in equally spaced windings across the entire duct cross-section. The probe must not touch the duct wall (see Figure 2).

Mounting Positions



Figure 1. Permissible Mounting Positions.

Mounting Examples

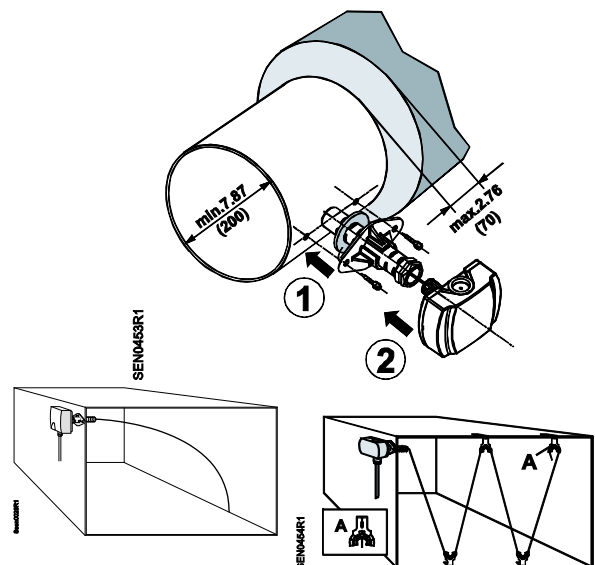

Figure 2. Installation.

Mounting Instructions are printed on the packaging.

The installation is now complete.

Wiring Diagrams

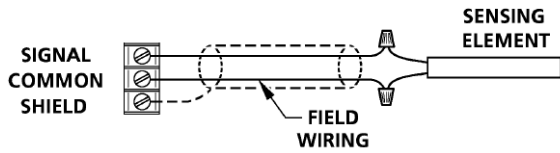

Figure 3. Passive Resistance Elements (QAM2112/2130.xxx).

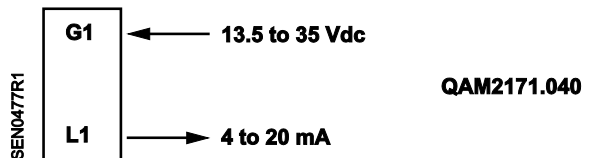
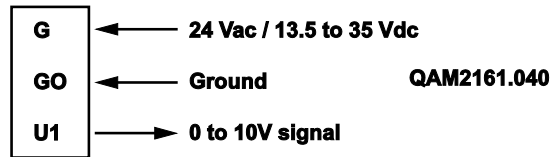
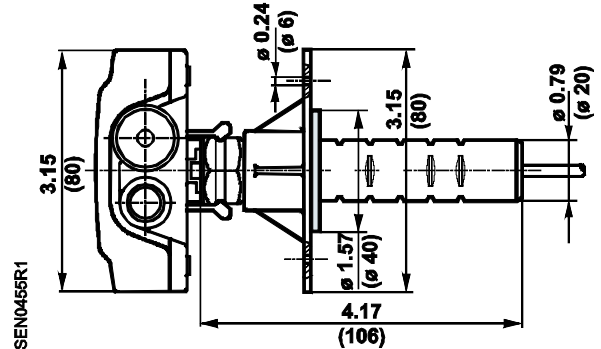
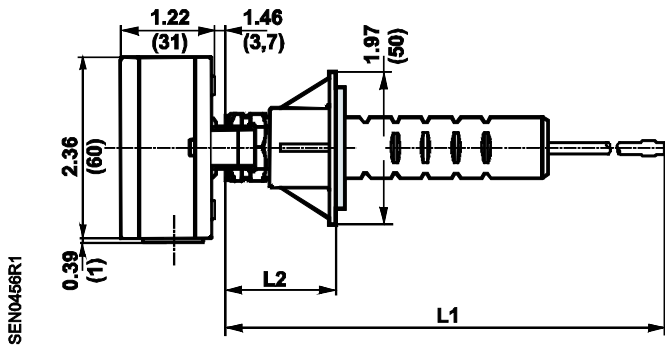
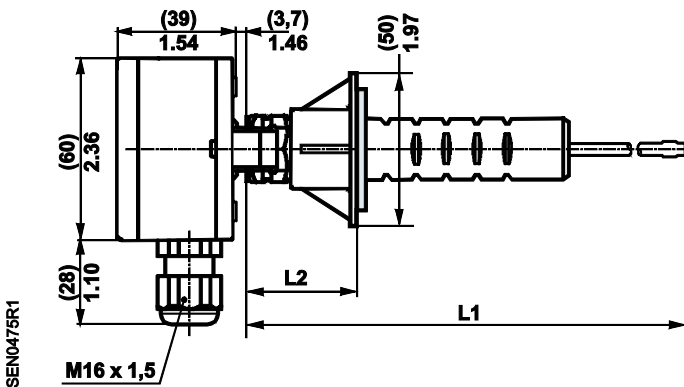

Figure 4. Active Output Sensors (QAM21x1.040).

Dimensions



Passive Resistance Elements (QAM2112/2130.xxx)



Product Number	L1	L2	
		Max.	Min.
QAM2130.040	15.75 (400)		
QAM2112.040	15.75 (400)		
QAM2112.200	78.74 (2000)	3.81 (97)	1.46 (37)
QAM2161.040	15.75 (400)		
QAM2171.040	15.75 (400)		

Active Output Sensors (QAM21x1.040)

Figure 5. Dimensions in Inches (Millimeters).

Dimensions, Continued

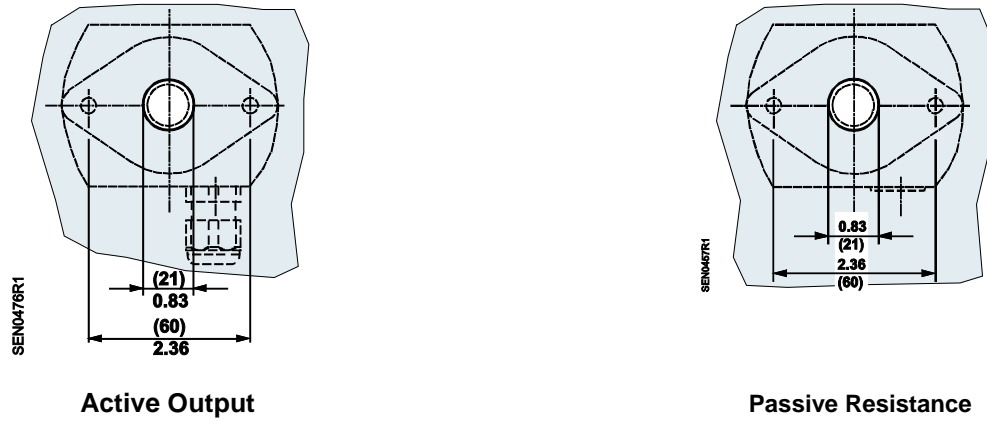

Figure 6. Drilling Plan in Inches (Millimeters).

Information in this publication is based on current specifications. The company reserves the right to make changes in specifications and models as design improvements are introduced. Products or company names mentioned herein may be the trademarks of their respective owners. © 2008 Siemens Industry, Inc.